

**HAUL-MASTER®**



# TRAILER SPARE TIRE CARRIER

**Model 93341**

## ASSEMBLY & OPERATING INSTRUCTIONS

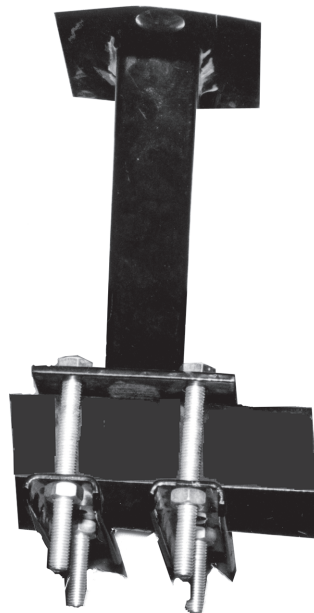

Due to continuing improvements, actual product may differ slightly from the product described herein.



3491 Mission Oaks Blvd., Camarillo, CA 93011  
Visit our Web Site at [www.harborfreight.com](http://www.harborfreight.com)

Copyright© 2005 by Harbor Freight Tools®. All rights reserved. No portion of this manual or any artwork contained herein may be reproduced in any shape or form without the express written consent of Harbor Freight Tools.

**For technical questions and replacement parts please call 1-800-444-3353.**

THANK YOU for choosing a **HARBOR FREIGHT TOOLS** product. For future reference, please complete the owner's record below:

**Model** \_\_\_\_\_ **Serial No.** \_\_\_\_\_ **Purchase Date** \_\_\_\_\_

SAVE THE RECEIPT, WARRANTY AND THESE INSTRUCTIONS. It is important that you read the entire manual to become familiar with the unit BEFORE you begin assembly.

The Trailer Spare Tire Carrier fits most trailer tongues up to 3" wide and 4" high. Will accept both 4 and 5 lug wheels. Easily mounts the spare tire up and away from the trailer.

**Technical Specifications**

Construction:	Heavy duty welded steel
Overall Dimensions:	10-1/4" L x 4"W x 6-1/4" H
Pre-drilled holes:	7/16" 360 degrees
Maximum Weight Capacity:	100 Lbs.
Weight:	6.6 Lbs.



***READ ALL INSTRUCTIONS BEFORE USING THIS PRODUCT!***

**Safety Warnings and Precautions**

**WARNING: When using product, basic safety precautions should always be followed to reduce the risk of personal injury and damage to equipment.**

**Read all instructions before using this product!**

1. **Keep work area clean.** Cluttered areas invite injuries.
2. **Observe work area conditions.** Keep work area well lighted.
3. **Store idle equipment.** When not in use, the Spare Tire Carrier must be stored in a dry location to inhibit rust. Always lock up products and keep out of reach of children.
4. **Use the right product for the job.** There are certain applications for which the Trailer Spare Tire Carrier was designed. Do not modify the Spare Tire Carrier and do not use this product for a purpose for which it was not intended.
5. **Check for damaged parts.** Before using any product, any part that appears damaged should be carefully checked to determine that it will operate properly and perform its intended function. Check for any broken or damaged parts and any other conditions that may affect its operation. Replace or repair damaged or worn parts immediately.  
**Note:** Dents or other imperfections in the Spare Tire Carrier may lead to a weakening of the structural strength of this product; do not use this Carrier if this type of damage is noted.
6. **Replacement parts and accessories.** When servicing, use only identical replacement parts. Use of any other parts will void the warranty.
7. **Do not operate product if under the influence of alcohol or drugs.** Read warning labels on prescriptions to determine if your judgment or reflexes are impaired while taking drugs. If there is any doubt, do not operate the product.
8. **Use eye protection.** Always wear ANSI approved impact safety goggles during assembly and when working with tools and equipment.
9. **The tire (not included) attached to this Carrier should be locked in place with nuts tightened to 90 ft-lbs.**

10. **Dress properly.** Do not wear loose clothing or jewelry as they can be caught in moving parts. Non-Skid footwear is recommended when assembling and when using the Spare Tire Carrier. Wear restrictive hair covering to contain long hair.
11. **Do not force this product.** Do not use inappropriate attachments in an attempt to exceed the capacity of the Spare Tire Carrier.
12. **Keep children away.** Children must never be allowed in the work area.
13. **Make certain that no persons or pets are under the Trailer Carrier or Trailer during loading.**

**Warning:** The warnings, cautions, and instructions discussed in this instruction manual cannot cover all possible conditions and situations that may occur. It must be understood by the operator that common sense and caution are factors which cannot be built into this product, but must be supplied by the operator.

### **Specific Trailer Tire Carrier Warnings and Precautions**

1. **Read and understand all instructions and safety precautions as outlined in the manufacturer's manual for the trailer you are using.** Make sure to mount the Trailer Carrier to the manufacturer's recommended mounting points.
2. **Examine the Trailer Spare Tire Carrier for structural cracks, bends, damage and any other condition that may affect the safe operation of the product.** Do not use if damaged in any way.
3. **Always keep hands, fingers, arms and feet out from under the Trailer Spare Tire Carrier when the trailer is moving.**
4. **It is the trailer owner's responsibility to make sure the usage of this product meets all local motor vehicle laws and regulations. Do not obscure marker, tail or running lights or license plate.**
5. **Make certain bracket or tire does not interfere with the trailers normal movement or blocks the driver's view.**
6. **For safety, it is recommended that 2 people install this product.**

### **Unpacking**

When unpacking your Trailer Spare Tire Carrier, make certain that all parts on page 5 of this manual are included. If any parts are missing or broken, please call **HARBOR FREIGHT TOOLS** at **1-800-444-3353**.

## Installation

1. Secure the unloaded trailer with wheel chocks (blocks) on a hard, flat surface capable of supporting the weight of the trailer, Trailer Spare Tire Carrier and required tools.
2. Raise the trailer tongue and secure it with two supports, one on each side of the trailer tongue.
3. Position the Mounting Bracket (2) in the correct location against the side of the trailer tongue.  
**Note:** The spare tire will be located to the side of the trailer tongue.  
**Note:** The angled Tire Mounting Plate should be angled upward (above) the position of the Trailer Tongue Plate.
4. Attach the Mounting Bar (1) to the Mounting Bracket (2). Set the Mounting Bars (1) (containing six holes) flat against the trailer tongue so that the edges of the Mounting Bars (1) curve out away from the trailer tongue. Insert four Hex Bolts (3) through the Mounting Plates (1) as close to the trailer tongue as possible. Slide on Washers (8), Spring Lock Washers (7) and thread on Nut (6). Use a torque wrench to tighten the Nuts (6) to 90 ft./Lbs.
5. Mount the tire on the Tire Mounting Plate with the valve facing outward so that the tire air pressure can be checked at any interval.

**Warning:**     **Make certain that the tire is centered on the Tire Carrier when mounted-see Figure 1.**

6. Insert Round Head Bolts (4) up through the Tire Mounting Plate and through the Wheel. Thread on Nylon Lock Nuts (5)-see Assembly diagram. Securely tighten and torque all hardware to 90 ft./lbs.

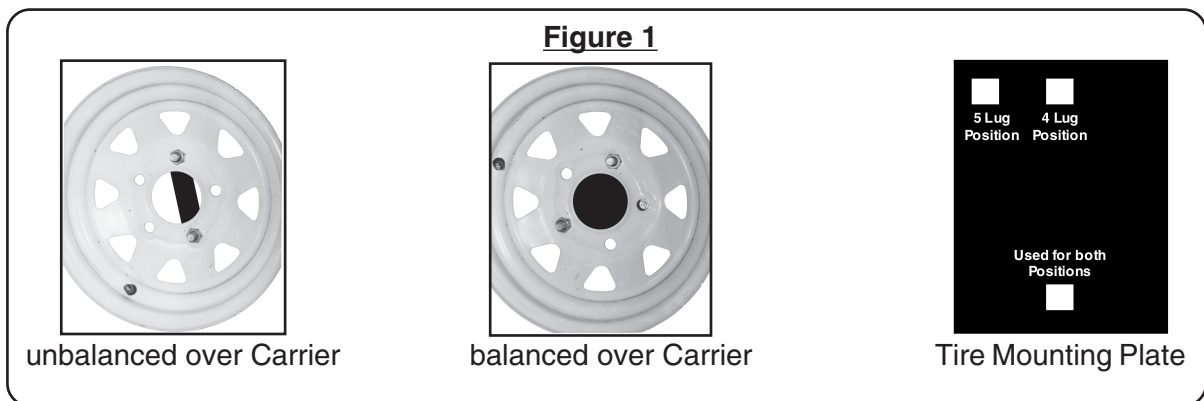

## Maintenance

Before each use, inspect the Spare Tire Carrier for its general condition. Check for loose bolts, cracked, bent or broken parts and any other condition that may affect its safe operation.

## Parts List

Part #	Description	Quantity	Part #	Description	Quantity
1	Mounting Bar	2	5	Nylon Lock Nut	2
2	Mounting Bracket	1	6	Nut	4
3	Hex Bolt	4	7	Spring Lock Washer	4
4	Round Head Bolt	2	8	Washer	4

**Note:** Some parts are listed and shown for illustration purposes only and are not available individually as replacement parts.

## Parts Assembly Diagram

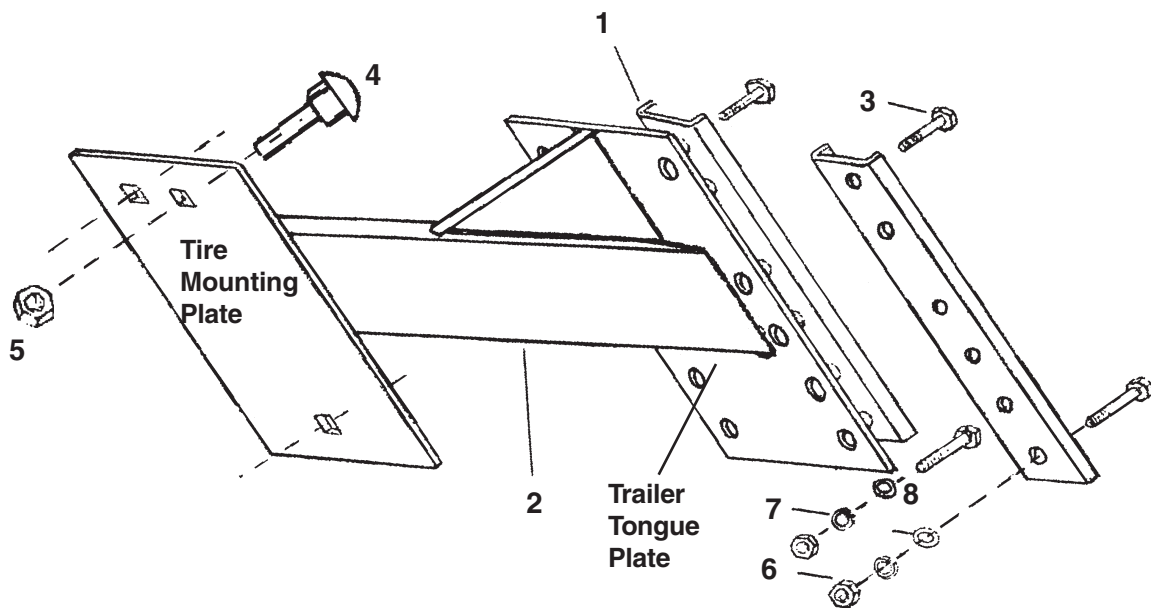

**PLEASE READ THE FOLLOWING CAREFULLY**

**THE MANUFACTURER AND/OR DISTRIBUTOR HAS PROVIDED THE PARTS DIAGRAM IN THIS MANUAL AS A REFERENCE TOOL ONLY. NEITHER THE MANUFACTURER NOR DISTRIBUTOR MAKES ANY REPRESENTATION OR WARRANTY OF ANY KIND TO THE BUYER THAT HE OR SHE IS QUALIFIED TO MAKE ANY REPAIRS TO THE PRODUCT OR THAT HE OR SHE IS QUALIFIED TO REPLACE ANY PARTS OF THE PRODUCT. IN FACT, THE MANUFACTURER AND/OR DISTRIBUTOR EXPRESSLY STATES THAT ALL REPAIRS AND PARTS REPLACEMENTS SHOULD BE UNDERTAKEN BY CERTIFIED AND LICENSED TECHNICIANS AND NOT BY THE BUYER. THE BUYER ASSUMES ALL RISK AND LIABILITY ARISING OUT OF HIS OR HER REPAIRS TO THE ORIGINAL PRODUCT OR REPLACEMENT PARTS THERETO, OR ARISING OUT OF HIS OR HER INSTALLATION OF REPLACEMENT PARTS THERETO.**